



GE Fanuc, Wonderware and Satel in the monitoring - controlling system applied in Wodociągi Kieleckie [Kielce Waterworks]

Zakład Uzdatniania Wody w Zagnańsku [ZUW] is a water treatment plant including water intakes in Zagnańsk. It is owned by Wodociągi Kieleckie Sp. z o. o. and constitutes a part of the system ensuring water supply for the city of Kielce.

In order to improve the efficiency of ZUW Zagnańsk and control of the water intakes, the board of directors decided in 1999 to implement a monitoring - controlling system for the facilities mentioned above. The task was entrusted to Techno-Progress Sp. z o. o., a company based in Krakow.

In accordance with the requirements of Wodociągi Kieleckie, the solutions applied were based on standard products. The controlling system was built on the basis of VersaMax programmable controllers manufactured by

GE Fanuc. For the visualisation of the process control at the intakes and ZUW, the company selected InTouch 7.1 runtime software developed by Wonderware, version for 100-points, run on two computers HP Vectra with Windows NT 4.0, and integrated within Ethernet network. One of the computers was installed in the dispatch room, and the other, acting as a backup unit, in the office of ZUW manager.

The communication between the controllers installed at the intakes and the computer at the Dispatch Station takes place via SATELLINE-2ASxE radio modems produced by SATEL. The controller installed in ZUW is cable connected to the computer located at the Dispatch Station. In both cases the transmission of data occurs on the basis of Modbus RTU protocol.

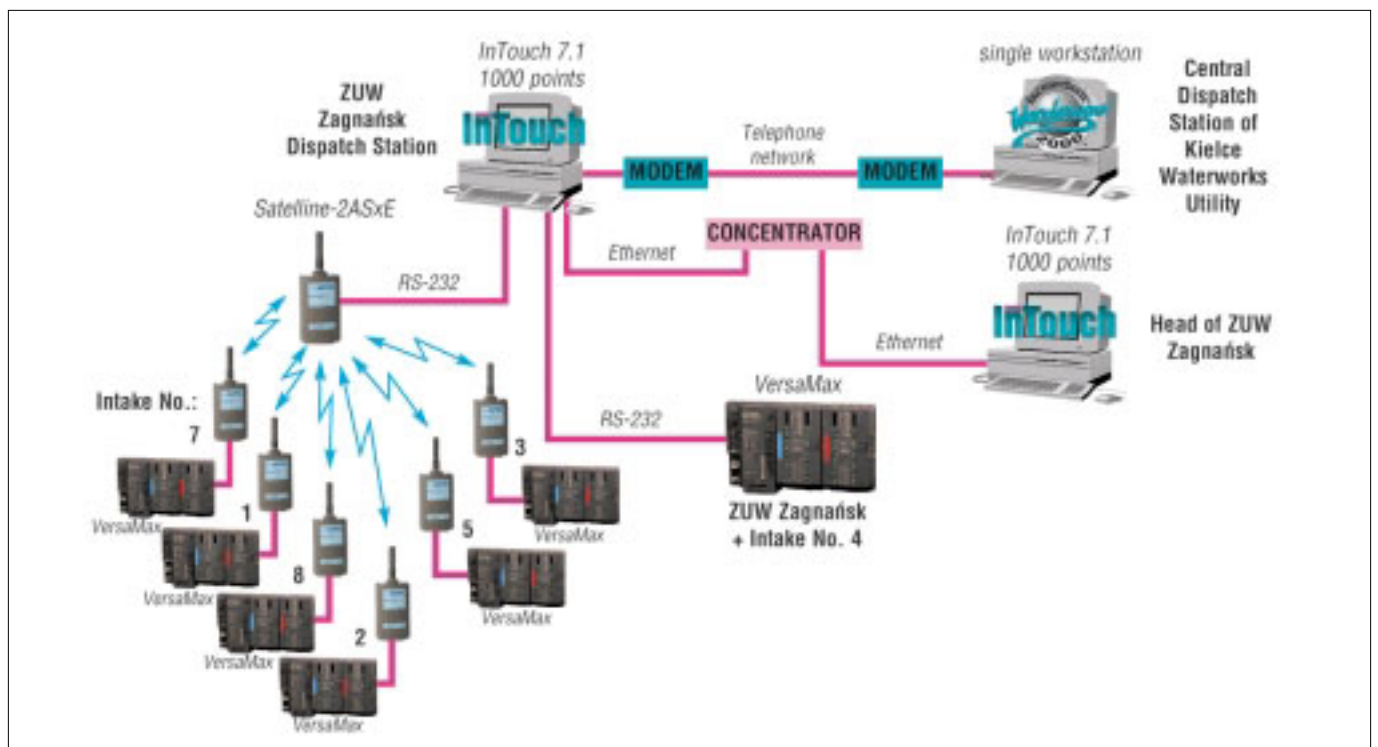

Diagram of the controlling system

The GE Fanuc VersaMax controllers installed in ZUW and at the intakes perform the following tasks:

- acquisition of measurement data from water intakes located within the ZUW area and in the neighbourhood- analogue signals
- acquisition of data about the operating conditions of the pumps and submersible pumps installed at the intakes - digital signals
- generating of signals related to alarm conditions and failures
- performing of control operations on throttle valves in order to maintain proper delivery of the pumps at the intakes and artesian wells
- calculation of the running time of the pumps,
- calculation of the output of water and the delivery of the pumps in artesian wells on the basis of impulses generated by water meters.

The visualisation application, developed on the basis of the InTouch 7.1 software, is composed of 69 different screens including, for example, main menu, general engineering diagram and detailed diagrams, alarm screens, trend displays and information screens.

The alarms coming from the sites are indicated:

- in graphic form on zoom-in screens
- in writing, in the alarm windows
- through audio signals.

Separating the alarm groups enables the operator

to browse among the emergencies and alarms registered. Reports on water production and running time of the pumps at artesian wells and pump units at the intakes, can be generated on daily or monthly basis.

The monitoring - controlling system implemented in ZUW in Zagnańsk provides the operator with the opportunity to exercise full control over the work of the intakes and ZUW itself. The operator can not only follow the functioning of the sites, but also adjust such values as delivery at specific intakes and pump units, by setting selected degrees of throttle valve opening. Automatically generated reports on water output allow to reduce the vehicle use expenditures. Thanks to the wireless data transfer provided by the SATELLINE radio modems, no daily trips are required to get the readings of the water meters installed at the intakes. Another advantage of the system is a quicker detection of and faster response to failures.

An interesting aspect is that the monitoring - controlling system includes a security-related function, important both for the 'producer' of water and for the recipients.

The system described above was designed and implemented in its entirety by

**Techno-Progress Sp. z o. o., ul. Stachowicza 5,
30-103 Krakow,
tel./fax (012) 422-60-17, 422-62-49,
e-mail: techno-progress@bci.krakow.pl.**

Mariusz Bzdeń, Józef Chmiel, Rafał Rębacz (Techno-Progress Kraków)



Manufacturer:

Satel Oy, Meriniitynkatu 17, P.O.Box 142, FIN-24101 Salo
Tel. +358 02 777 7800, fax +358 02 777 7810, E-mail info@satel.fi
www.satel.fi